

## KW WEIGHING INDICATOR

### ▶ FEATURES

- large LCD display with LED backlight display
- Rechargeable battery operation, up to 90 hours of continuous use
- Programmable to meet your needs
- Function include units conversion, counting, checkweighing, accumulation, animal scale.

### ▶ OPTIONAL

- RS-232 interface can connect LP-50 label printer, TPuP mini printer or computer

### ▶ DIMENSION (mm)

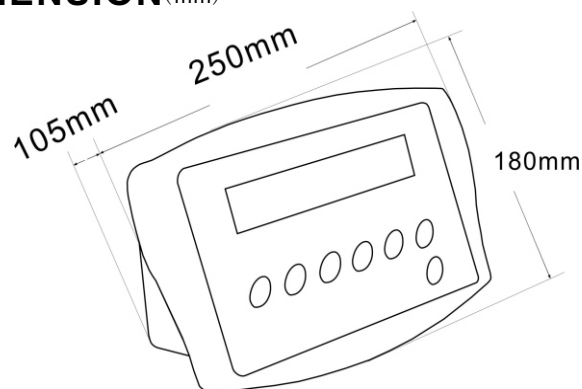

### ▶ SPECIFICATIONS

MODEL	KW
Display	24mm LCD display, with white color LED backlight
Operate temp	0°C~+40°C
ADC	sigma delta
ADC update	≤1/10 second
Housing	ABS plastic
Internal counts	600,000
Rating	AC adapter(9V/800mA)
Max. Divisions	30,000d(Max) 6,000d(approved)
Keypad	7 keys membrane switch
Power	AC adapter (9V/800mA) rechargeable battery (6V/4Ah)
Gross weight	2.5kg
Packing	Master carton 4 in 1 packing ,Gross weight 11.5kg dimension 0.1.6m <sup>3</sup> 40 feet container can load 2020 machnie,20 feet container can load 1010 machine

